

Large chamber type level gauge

Model : L110 (Reflex type)
L210 (Transparent type)

Spec. sheet no. LD01-02

Description

When liquids boil, bubbling makes the surface level indistinct. In this type of gauge, the larger volume of the liquid chamber reduces bubbling, there by facilitating level reading. It is also frequently used for dense, viscous liquid. The body is made of A106 Gr.B or stainless steel pressure pipe, and is fitted for high-viscosity fluids and slurry, the liquid path at valves, and at joints of the gauge body, is normally so restricted that changes in liquid level cannot be readily observed.

It is therefore possible to use connecting pipes and valves like those shown in the photographs above. Which are of the same diameter as the liquid chamber.



Model : L110
(Reflex type)



Model : L210
(Transparent type)

Model

Model - L110 (Reflex type)

Chamber material

Carbon steel, Stainless steel

Max. pressure

4 MPa

Vessel connection

¾", 1", 1½" and 2"

Model - L210 (Transparent type)

Chamber material

Carbon steel, Stainless steel

Max. pressure

4 MPa

Vessel connection

¾", 1", 1½" and 2"

Dimension

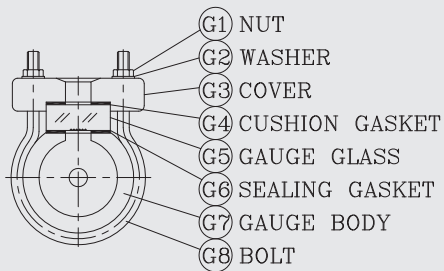
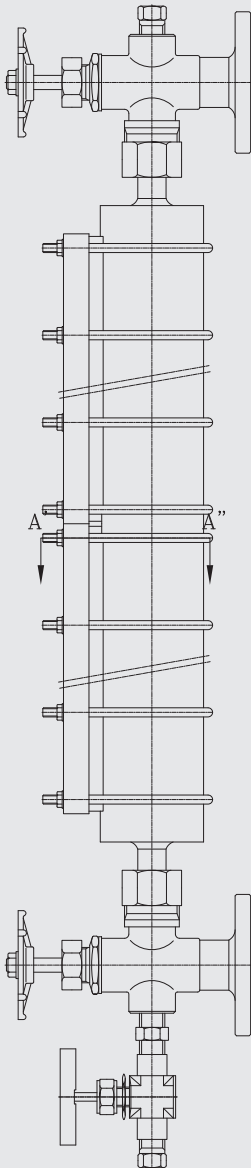

L110 (Reflex type)

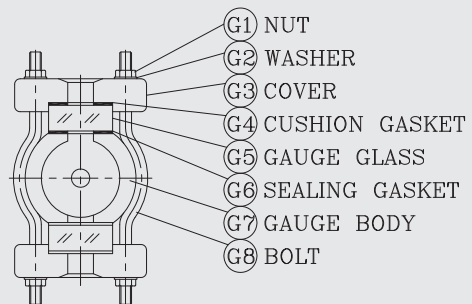
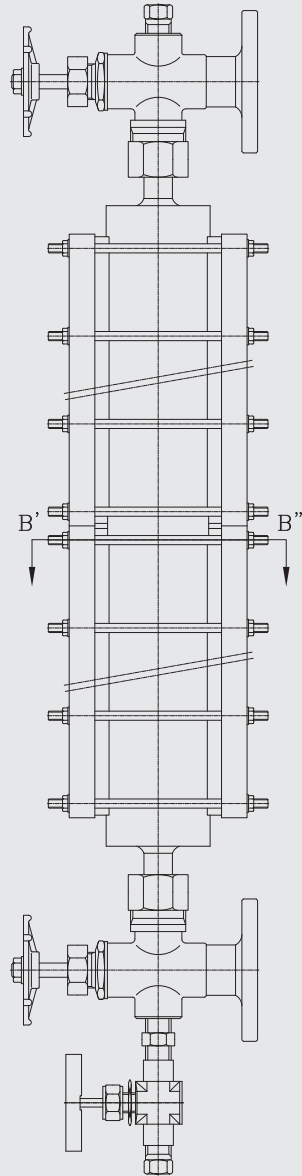

L210 (Transparent type)